

Heat Transfer

11-1a1

Conduction

Fourier's Law of Conduction

Rate of Heat Transfer:

$$\dot{Q} = -kA \frac{dT}{dx} \quad 31.1$$

- Through a wall:

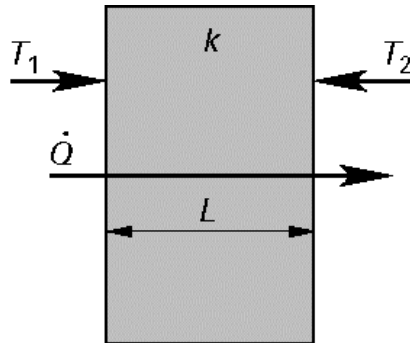

$$\dot{Q} = -\frac{kA(T_2 - T_1)}{L} \quad 31.2$$

$$Q = \dot{Q}t$$

Thermal Resistance: $R = \frac{L}{kA}$

- Through a composite wall:

Figure 31.1 Composite Slab Wall

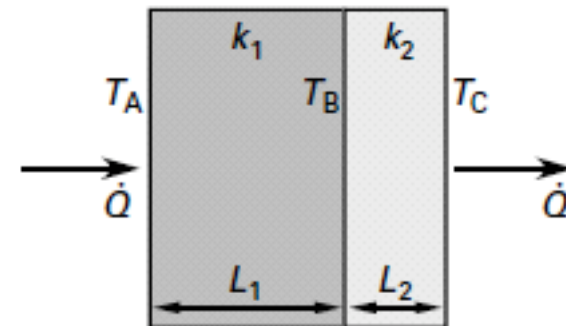

$$R_{\text{total}} = R_1 + R_2 = \frac{L_1}{k_1 A} + \frac{L_2}{k_2 A}$$

Heat Transfer

11-1a2

Conduction

- Through a cylindrical wall of length L :

Figure 31.2 Cylindrical Wall

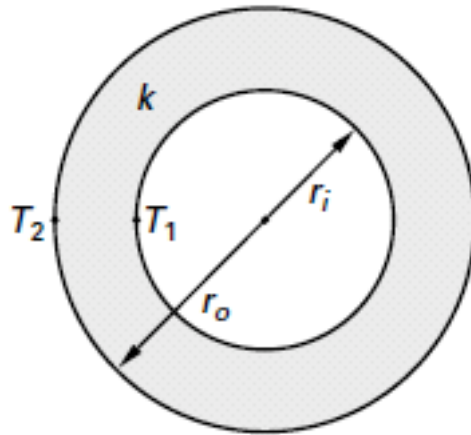

$$R = \frac{\ln \frac{r_2}{r_1}}{2\pi kL}$$

$$\begin{aligned} \dot{Q} &= \frac{A_m k (T_1 - T_2)}{L_{\text{radial}}} \\ &= \frac{2\pi k L_{\text{longitudinal}} (T_1 - T_2)}{\ln \left(\frac{r_o}{r_i} \right)} \end{aligned} \quad 31.8$$

Heat Transfer

Convection

Convection Heat Transfer $\dot{Q} = hA(T_w - T_\infty)$ 31.9

For a straight fin:

Figure 31.3 Finite Straight Fin

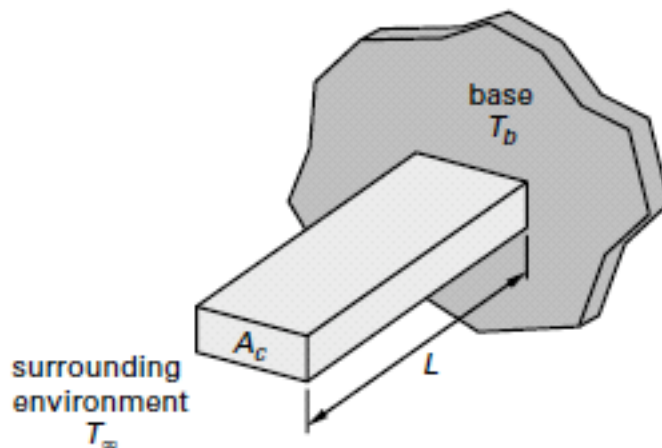

- P = exposed perimeter
- k = thermal conductivity
- A_c = cross-sectional area
- T_b = temperature of fin base
- T_∞ = fluid temperature

$$\dot{Q} = \sqrt{hPkA_c} \times (T_b - T_\infty) \tanh h(mL)$$

[rectangular fin] 31.17

$$m = \sqrt{\frac{hP}{kA_c}} \quad 31.18$$

$$L_c = L + \frac{A_c}{P} \quad 31.20$$

Radiation

$$\dot{Q}_{\text{black}} = \epsilon \sigma A T^4 \quad 31.15$$

ϵ = emissivity

$\sigma = 5.67 \times 10^{-8} \text{ W/m}^2 \cdot \text{K}^4$ (Stefan-Boltzmann constant)

Black Body vs. Gray Body

Black Body:

emissivity(ϵ) = absorptivity (α) = 1

Gray Body:

$\epsilon = \alpha$, and both are between 0 and 1

Radiant Heat Transfer

$$\dot{Q}_{12} = \sigma A_1 F_{1-2} (T_1^4 - T_2^4) \quad 31.16$$

For any body, radiation must be absorbed, reflected, or transmitted through:

$$\alpha + \rho + \tau = 1 \quad 31.10$$

$$\alpha + \rho = 1 \quad [\text{opaque body; } \tau = 0] \quad 31.12$$

$$\alpha + \rho = \epsilon + \rho = 1 \quad [\text{gray body; } \tau = 0; \alpha = \epsilon] \quad 31.13$$

$$\alpha = \epsilon = 1 \quad \left[\begin{array}{l} \text{black body; } \tau = 0; \\ \rho = 0; \alpha = \epsilon \end{array} \right] \quad 31.14$$